



Autopilot Servo Installation Guide

RV4, RV8 Pitch

This product is not approved for installation in type certificated aircraft

Document 101046-002, Revision F

January, 2013

Copyright © 2009-2013 by Dynon Avionics, Inc.

Permission to print this this manual is granted to third parties



Contact Information

Dynon Avionics, Inc.
19825 141st Place NE
Woodinville, WA 98072
Phone: (425) 402-0433 - 8:00 AM – 5:00 PM (Pacific Time) Monday – Friday
Dynon Technical Support available 7:00 AM–4:00 PM (Pacific Time) Monday – Friday
Email: support@dynonavionics.com
Fax: (425) 984-1751

Dynon Avionics offers online sales, extensive support, and frequently updated information on its products via its Internet sites:

www.dynonavionics.com –Dynon Avionics primary web site; including:
docs.dynonavionics.com – Current and archival documentation including Installation Guides.
downloads.dynonavionics.com – Software downloads.
support.dynonavionics.com – Support resources.
store.dynonavionics.com – Dynon’s *secure* online store for purchasing all Dynon products 24 hours a day.
wiki.dynonavionics.com – Dynon’s Documentation Wiki provides enhanced, extended, frequently updated online documentation contributed by Dynon employees and customers.
forum.dynonavionics.com – Dynon’s Internet forum where Dynon customers can interact with each other and Dynon Avionics. A key feature of the forum is that it allows the exchange of diagrams, photos, and other types of files.
newsletter.dynonavionics.com – Dynon’s email newsletter.
blog.dynonavionics.com – Dynon’s blog where you can find new and interesting Dynon-related content.
register.dynonavionics.com – Register your Dynon Avionics product.
license.dynonavionics.com – Redeem certificates for navigation mapping software, synthetic vision, and other features for license codes that add new functionality to your SkyView system.

Copyright

©2008-2012 Dynon Avionics, Inc. All rights reserved. No part of this manual may be reproduced, copied, transmitted, disseminated or stored in any storage medium, for any purpose without the express written permission of Dynon Avionics. Dynon Avionics hereby grants permission to download a single copy of this manual and of any revision to this manual onto a hard drive or other electronic storage medium to be viewed for personal use, provided that such electronic or printed copy of this manual or revision must contain the complete text of this copyright notice and provided further that any unauthorized commercial distribution of this manual or any revision hereto is strictly prohibited.

Information in this document is subject to change without notice. Dynon Avionics reserves the right to change or improve its products and to make changes in the content without obligation to notify any person or organization of such changes. Visit the Dynon Avionics website (www.dynonavionics.com) for current updates and supplemental information concerning the use and operation of this and other Dynon Avionics products.



Servo Mounting Instructions – RV-4/8 Fuselage Pitch Kit

Kit Contents		
Dynon Part #	QTY	Part Description
100836-000	2	Large Male Rod End
100874-000	1	RV4,8 Pitch Bracket - Right
100874-001	1	RV4,8 Pitch Bracket - Left
100966-000	1	Aluminum Pushrod Tube - 2.25"
100975-002	2	AN315-4R Jam Nut
100976-011	2	AN365-1032A Nylon Insert Locknut
100977-000	2	AN970-3 Large Flat Washer
100978-003	8	AN960-10 Small Flat Washer *(1)
100979-002	2	MS35333-39 #10 Internal Star Washer
100981-001	1	AN3H-4A Bolt - ½"
100981-002	1	AN3H-5A Bolt - 5/8" *
100981-005	1	AN3H-10A Bolt - 1"
100981-006	1	AN3H-11A Bolt - 1 1/8"
100981-008	1	AN3H-13A Bolt - 1 3/8"
100981-010	1	AN3H-15A Bolt - 1 5/8" *
100982-003	1	Aluminum Spacer - 0.750"
100982-004	1	Aluminum Spacer - 0.875" *
101197-010	1	AN4H-15A Bolt - 1 5/8" *

* Used with "RV-8 Fuselage Kit – 1", shipped post-September 2006

The RV-4/8 fuselage pitch servo mounting kit includes left and right brackets, pushrod linkage, and most of the required fasteners to mount the servo and properly link it to the aircraft control system. Dynon has designed the servo mounting brackets to be used in both the Vans RV-4/8 Fuselage Kits manufactured before September 2006, as seen on pages 7-10, and the RV-8 Fuselage Kit - 1 (Quick Build Kit) manufactured after September 2006, as seen on pages 11-13. This kit also includes additional fasteners for use in Vans RV-8 Fuselage Kit – 1. All Dynon-supplied parts are illustrated in dark grey to distinguish them from existing aircraft hardware.

When installing this kit in an RV-4 or in an RV-8 manufactured before September 2006, the existing pitch bell crank brackets must be removed and the new brackets match-drilled prior to installation. Fasten the existing brackets together with a short bolt thru the bell crank mounting holes. Transfer the rivet pattern to a piece of scrap aluminum plate by clamping the bolted-together brackets along an edge of the plate; drill rivet-size matching holes in the plate. Note and mark the lengthwise



location of the bell crank mounting holes. Remove the original brackets and clamp the new brackets to the match-drill plate along the same edge and with the bell crank mounting holes aligned with the reference mark. Flip the brackets and match drilling plate upside down, and drill new rivet holes in the brackets. You may wish to trial assemble the pitch bracket assembly, as shown on page 8. This can be done on the bench, and the rod end bearing position can be adjusted per the figure on page 9.

Attach the new brackets to the aircraft using the original rivet holes. The bell crank mounting hole should be in exactly the same position it was with the original brackets. It is up to the installer to supply the bracket mounting fasteners depending on what method was used to secure the original equipment (not available from Dynon).

When installing this kit in an RV-8 manufactured after September 2006, it is up to the installer to align and fasten the brackets to the fuselage. Start by removing the bell crank nut and bolt to align the largest hole in the brackets with the holes in the upward-bent bell crank pivot bearing supports, as shown on page 12. Dynon recommends temporarily using the supplied AN4H-15A bolt as a locator while drilling through the brackets and fuselage. Fasten the brackets to the fuselage using the installer's preferred method and hardware (not available from Dynon).

Drill the bell crank according to the drawing on page 10. Use a supplied AN960-10 washer as a support between the two halves of the bell when the linkage is fastened.

For a pre-September 2006 aircraft, install the supplied AN3H-4A bolt, MS35333-39 star washer, and AN960-10 flat washer through the inside of the installed brackets and into the servo (in the hole closest to the bell crank pivot bearing) referring to the drawing for servo orientation. Sandwich the bell crank and the supplied 0.750" spacer between the mounted left bracket and the right bracket. Pass the AN3H-13A bolt, MS35333-39 star washer, and AN960-10 flat washer through the right bracket, spacer, left bracket, and tighten into the remaining hole of the servo.

For a post-September 2006 aircraft, install the supplied AN3H-5A bolt, MS35333-39 star washer, and AN960-10 flat washer through the inside of the installed brackets and into the servo (in the hole closest to the bell crank pivot bearing) referring to the drawing for servo orientation. Sandwich the bell crank, bent bell crank pivot bearing supports, and the supplied 0.875" spacer between the mounted left bracket and the right bracket. Pass the AN3H-15A bolt, MS35333-39 star washer, and AN960-10 flat washer through the right bracket, spacer, left bracket, and tighten into the remaining hole of the servo. Finally, replace the original AN4 bolt for the bell crank with the longer AN4H-15A bolt supplied with this kit.

With the brackets, servo, and drilled aircraft bell crank installed, the linkage must be assembled and mounted. Refer to the illustration and follow proper rod end installation techniques. Screw at least half of the threads on each rod end into the push rod. To prevent the possibility of the servo arm going over-center, the servo arm must **not** travel more than a total of +/-60° from neutral throughout the control system's range of travel. The linkage should be installed as close to the Dynon recommendation as possible, as changes will affect geometry. Dynon suggests installing the linkage at the outer-most hole of the servo arm. Changing this location will affect servo torque output, servo arm travel, control surface resolution, and the amount of force required to shear the safety screw, and should only be changed if the installer has an understanding of these implications. See the diagram on page 6 which illustrates the linear travel and available force for each mount point on standard-arm servos.

Thread both large rod ends with jam nuts into the supplied 2.25" tube. Standard mounting of the linkage to the servo arm will include the AN3H-10A bolt, AN970-3 large diameter flat washer (for capturing the rod end bearing), 2 AN960-10 flat washers on each side of the servo arm itself, and the AN365-1032A lock nut. The other end of the linkage will require the same type of stack-up, using the longer AN3H-11A bolt and capturing the washer sandwiched between the halves of the bell crank. When installing in an RV-8 manufactured after September 2006, use the additional supplied AN960-10 flat washer between the bell crank and rod end bearing to space the linkage away from the bell crank, as shown on page 11.

The distance between the servo arm and the control system attachment point must allow for the angle between the servo arm and the push rod to be at approximately 90° when the controls are at neutral. Use the adjustability in the rod ends to achieve this, and then tighten the jam nuts to lock the rod ends in place. Installers should always keep in mind the range of motion of the servo. Total servo arm travel is limited, but verify the arm/linkage do not interfere with anything during the full motion of the control stick. The built in control stops of the aircraft will limit the servo arm travel when installed correctly. We recommend the use of the optional Range of Motion Limiting Bracket, supplied with the servo to eliminate the chance of the servo arm going over-center. This bracket should not be used as a normal stop; the aircraft's built-in stops should always be the primary range limit.

Due to the thickness of the brackets used with this servo mounting kit, the screws supplied with the Range of Motion Limiting Bracket Kit will be too short. Either trim the stopper bracket until it does not interfere with the thick servo bracket, or supply a set of longer screws following the guidelines in the documentation of that kit. **Do not install screws that penetrate the servo enclosure more than 0.175"**.

Your servo(s) and AP74/76 (if ordered) came with a CD containing the latest documentation for all Dynon products (also available at dynonavionics.com). Please read through that documentation to understand the wiring and configuration process for your Autopilot system. We also maintain a collaborative set of this documentation, which is often updated with new information by both Dynon and fellow builders. Visit wiki.dynonavionics.com to view and contribute to the latest version of these documents.

You can also visit forum.dynonavionics.com to discuss and share installation notes, pictures, and suggestions with other builders.



Neglecting to properly install and/or use Dynon autopilot hardware may result in failures which could cause loss of aircraft control resulting in aircraft damage, personal injury or death.

Wiring Overview

The following diagram provides an overview of the autopilot-specific wiring installation. For the complete set of wiring and configuration instructions, please see the latest Installation Guide for your Dynon EFIS product. For a SkyView system please reference the **Autopilot Servo Installation, Configuration, and Calibration** chapter of your SkyView System Installation guide. For EFIS-D10A, EFIS-D100 or FlightDEK-D180 please reference the **Autopilot Installation and Configuration** chapter of each respective Installation Guide.

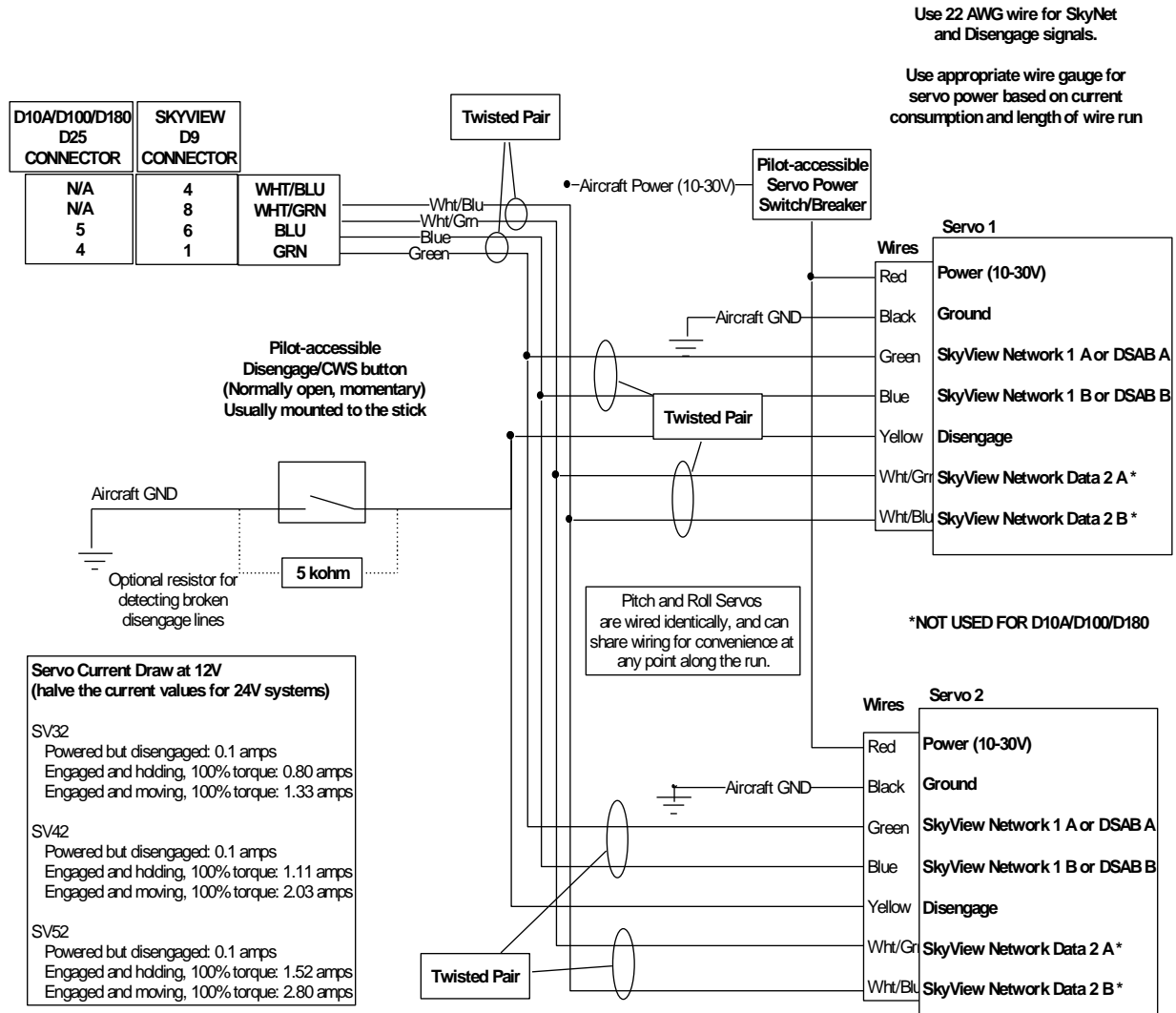



Servo Dimensions

Use the following dimensions (in inches) for reference when planning and implementing your installation.

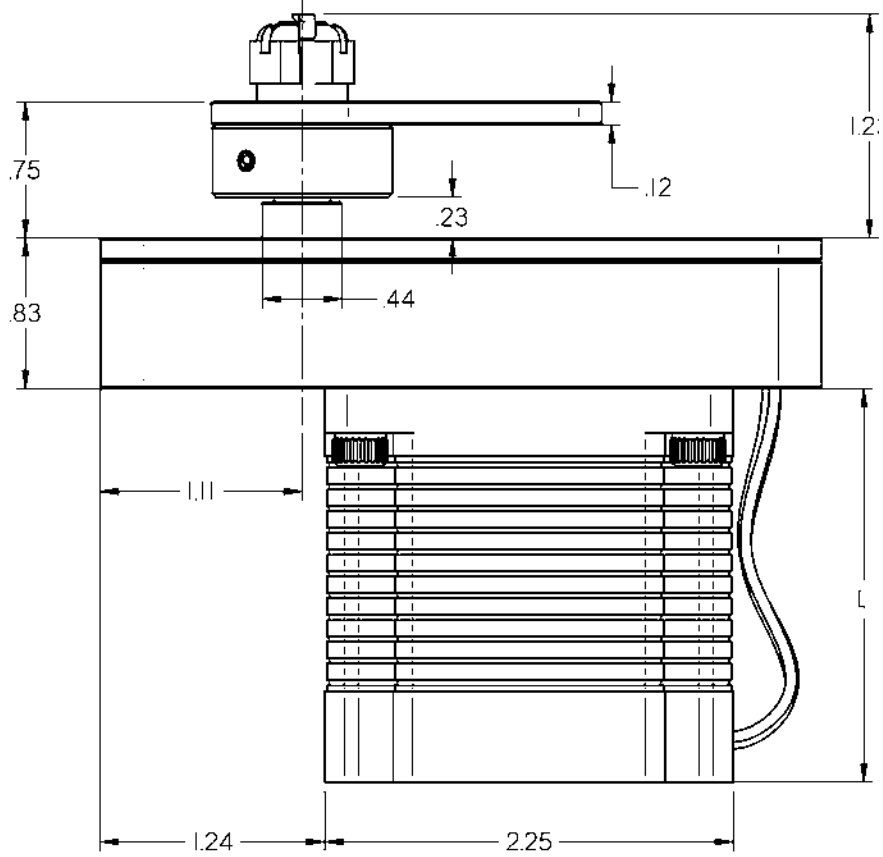
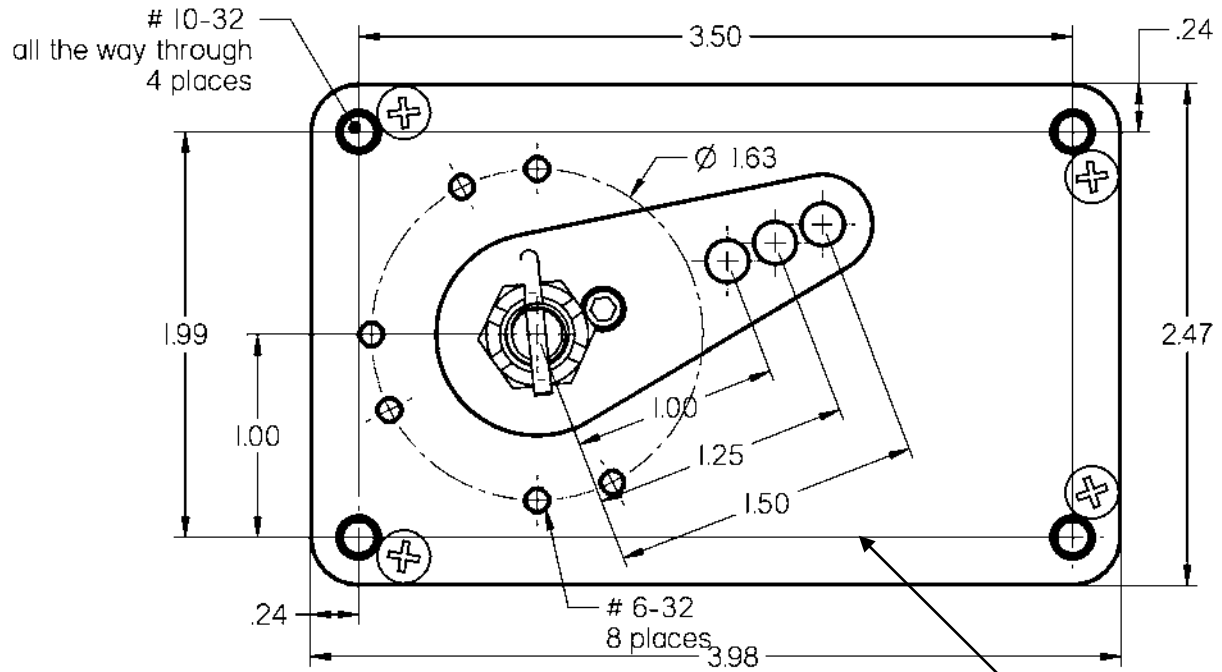

Long-arm variants
(not needed in most
installations) have
linkage mount holes
at 1.5", 1.75", and
2.0"

	L	Weight
SV32	2.17"	2 lb
SV42	3.10"	3 lb
SV52	4.02"	4 lb

Linkage mount position force and travel

The diagram below illustrates the maximum travel and force available at each linkage mounting point. As can be seen, the closer you mount the linkage to the shaft, the more force the servo can deliver. However, this also means the travel of the arm is shorter. Again, ensure that the servo arm is nowhere near going over-center throughout the entire range of the control system.

Position A should be used in most RV-4/8 pitch installations. Modify mount position with caution and take all precautions to ensure that a near over center condition cannot occur.

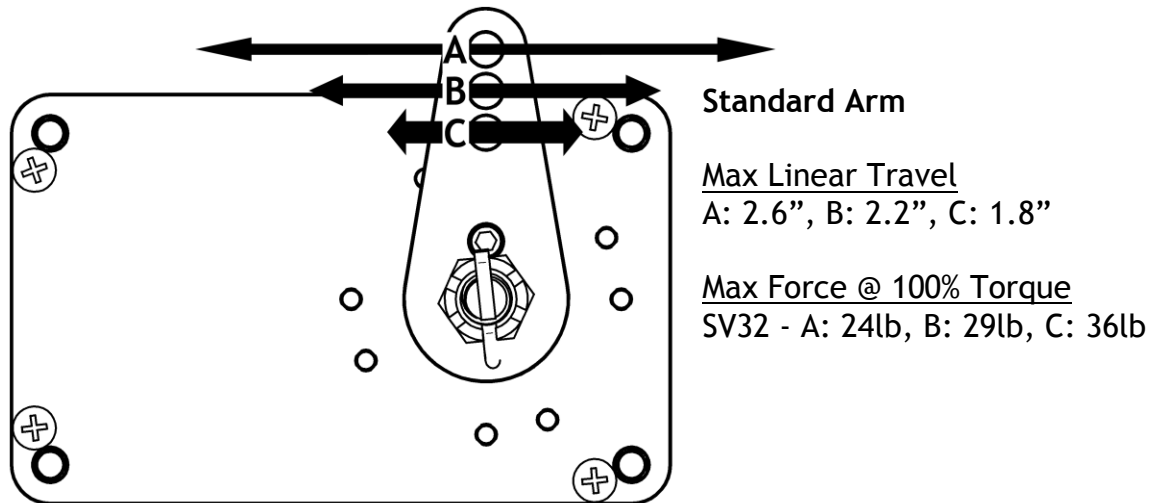

- ! The autopilot safety shear screw should **NEVER** be removed or adjusted during this operation. If the shear screw has broken and needs replacement, there is specific documentation available for this purpose at <http://docs.dynonavionics.com>.

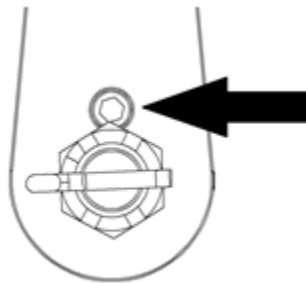

Mounting Drawings

The following pages provide detailed views of the mounting and assembly of the servo and this kit. Two sets of diagrams are shown for the assembled kit:

1. All RV-4 fuselages. All RV-8 fuselages built from kits manufactured prior to September 2006.
2. All RV-8 fuselages built from kits manufactured after September 2006.

The bell crank drill location is the same for both kits.

Bell Crank Drill Location

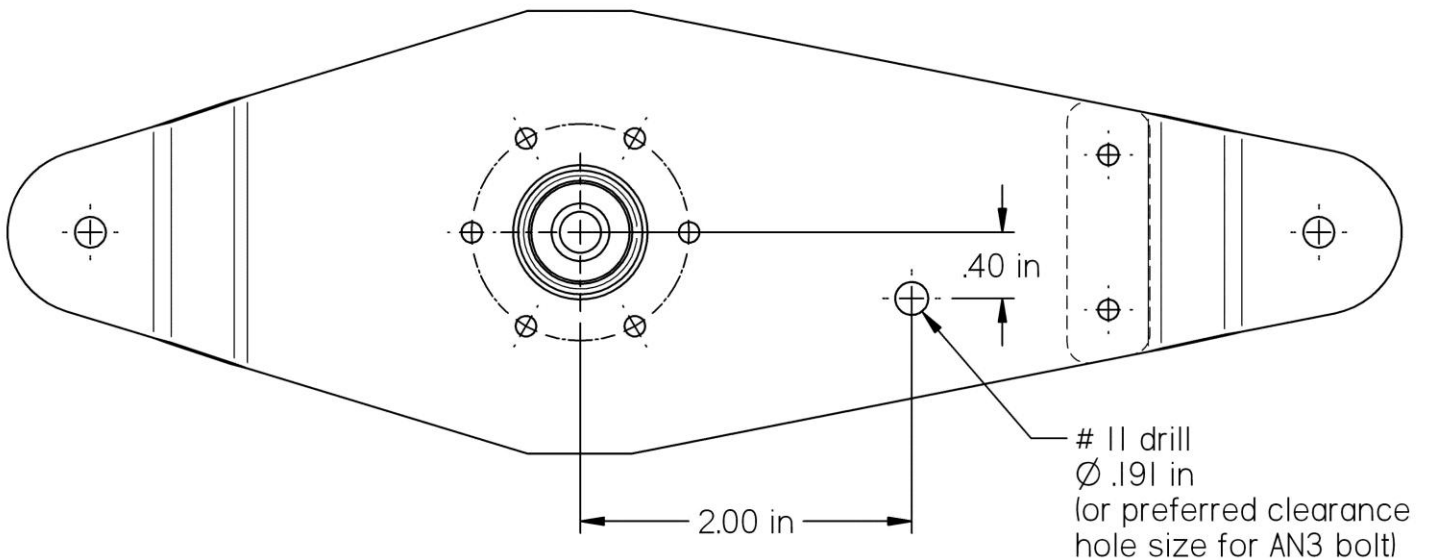

RV 4 & 8 Pitch
Bellcrank Modification
04/30/2009



RV-4 and Pre-Sept-2006 RV-8 Exploded View

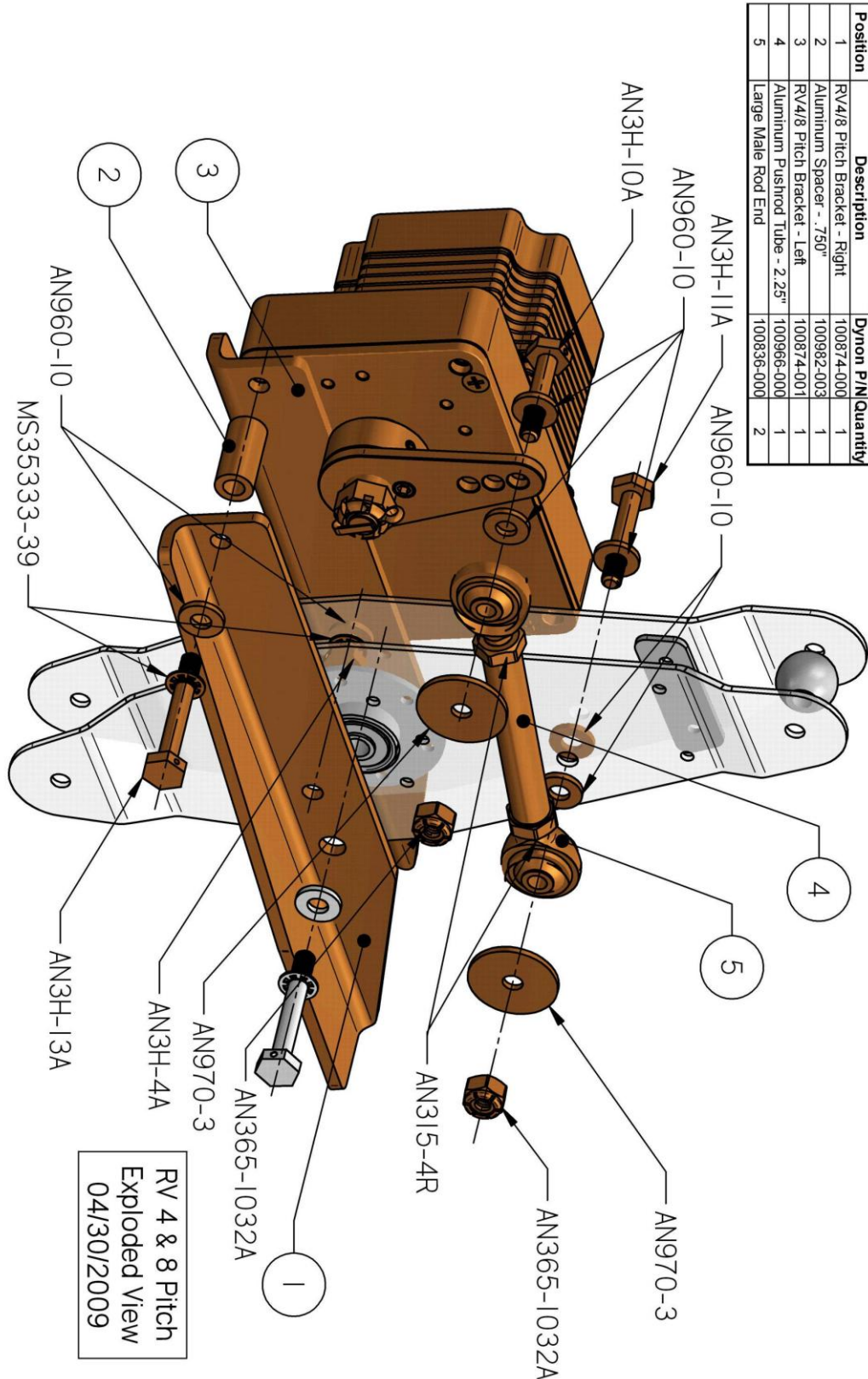

RV 4 & 8 Pitch
Exploded View
04/30/2009



RV-4 and Pre-Sept-2006 RV-8 Assembled View

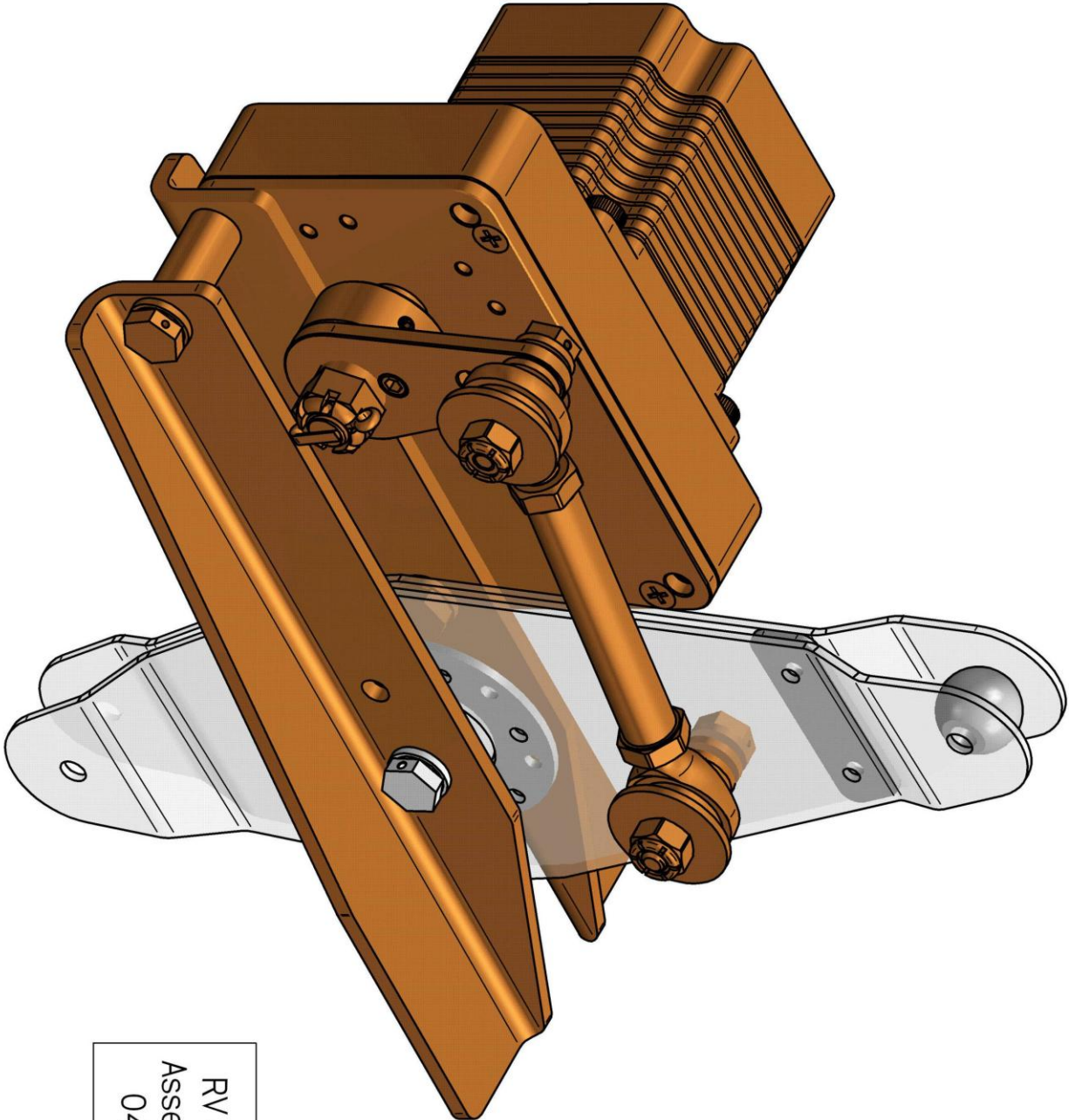

RV 4 & 8 Pitch
Assembled View
04/30/2009



RV-4 and Pre-Sept-2006 RV-8 Pushrod Spacing View

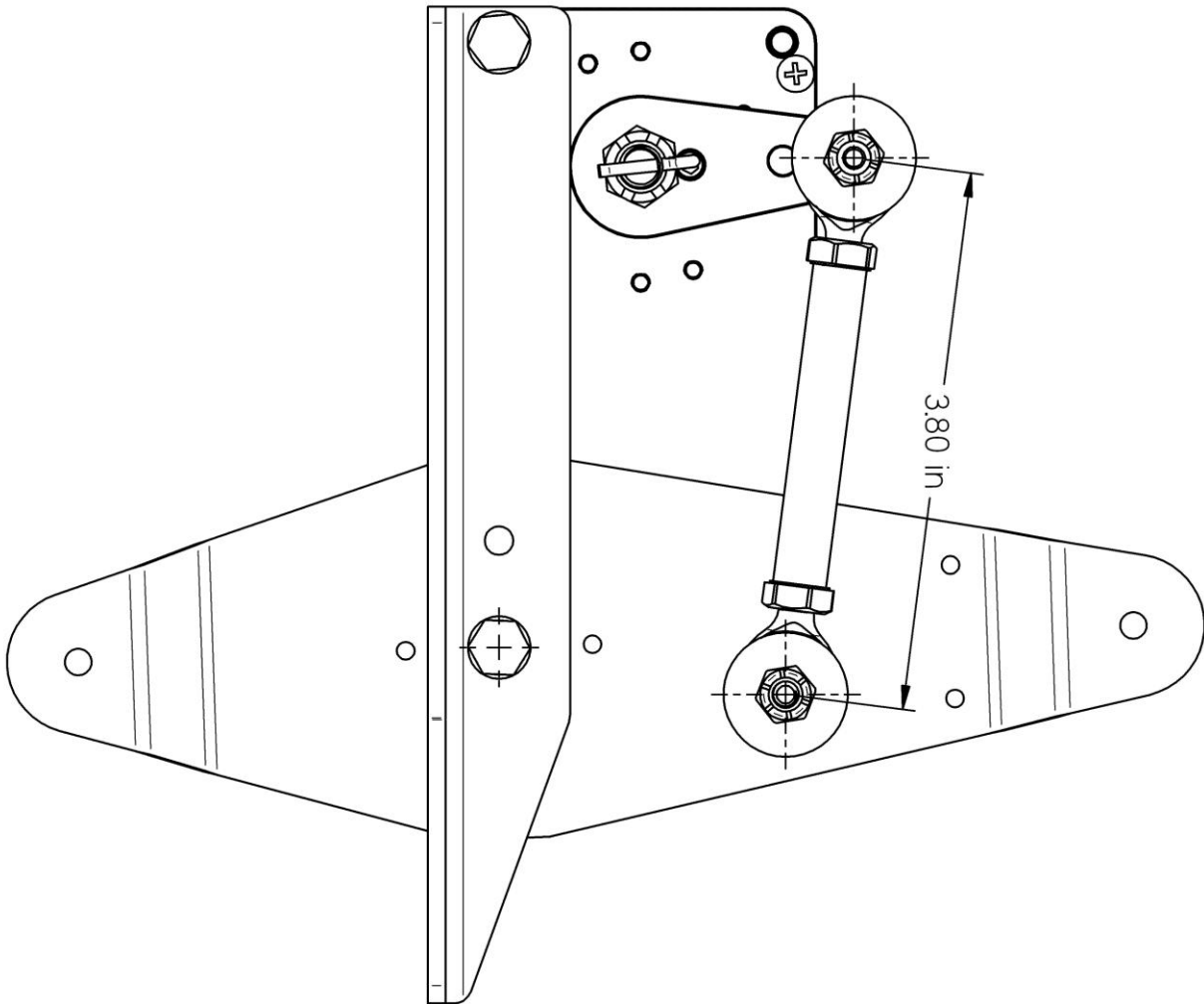

RV 4 & 8 Pitch
Pushrod Spacing
04/30/2009



Post-Sept-2006 RV-8 Exploded View

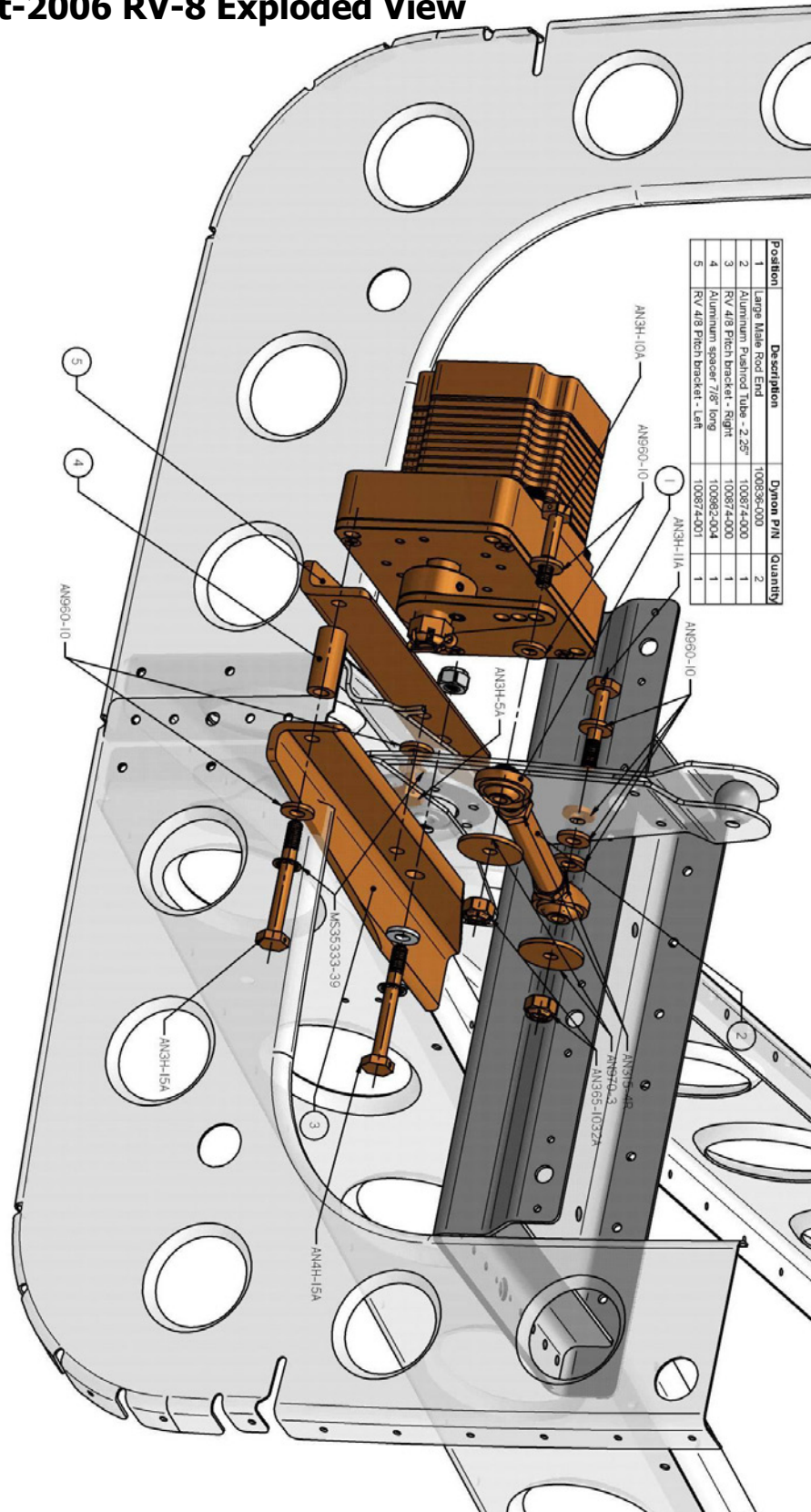

Position	Description	Dynon P/N	Quantity
1	Large Male Rod End	100836-000	2
2	Aluminum Pushed Tube - 2.25"	100874-000	1
3	RV 4/8 Pitch bracket - Right	100874-000	1
4	Aluminum spacer 7/8" long	100982-004	1
5	RV 4/8 Pitch bracket - Left	100874-001	1

Post-Sept-2006 RV-8 Assembled Side View

This view shows the idea pushrod spacing as well as the bell crank drill hole location.

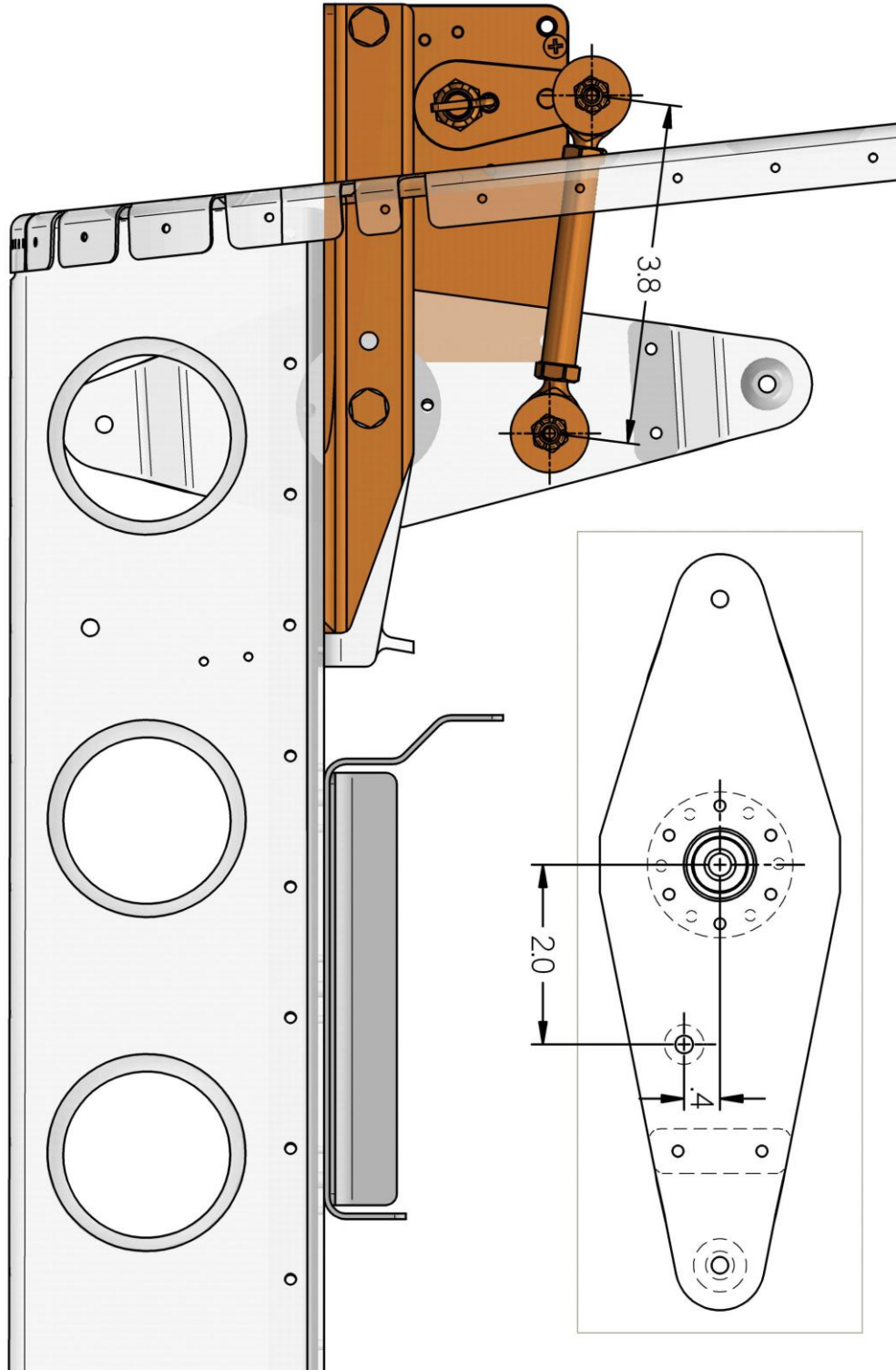



Post-Sept-2006 RV-8 Assembled Back View

